

innovAg

MiniTest II

**Dairy Vacuum
&
Pulsation Meter**

User Manual

Part No. DR51-0028-05

FCC Compliance Statement

This device complies with Part 15 of the FCC rules. Operation is subject to the following two conditions:

1. This device may not cause harmful interference, and
2. This device must accept any interference received, including interference that may cause undesired operation.

Declaration of Conformity

Standards to which Conformity is declared:

- EN 61000-4-2
- EN 61000-4-3
- EN 61000-6-1
- EN 61000-6-2
- EN 61000-6-4
- IEC 61326-1:2005
- EU Directive 2002/95/EC
- EU Directive 2004/108/EC
- China RoHS (See following page)

Manufacturer's Name: InnovAg Pty. Ltd.

Manufacturer's Address: 82 Victoria St.
Sandringham
Victoria 3191
Australia

Type of Equipment: Pulsation Tester/ Vacuum Gauge

Brand Name: MiniTest II

Model Number: DR40-0080

零件项目(名称) (Component Name)	有毒有害物质或元素(Hazardous Substances or Elements)					
	铅 Lead (Pb)	汞 Mercury (Hg)	镉 Cadmium (Cd)	六价铬 Chromium VI Compounds (Cr6+)	多溴联苯 Poly- brominated Biphenyls (PBB)	多溴二苯醚 Poly-brominated Diphenyl Ethers (PBDE)
印制电路主要配件 (Main Printed Circuit Assembly)	○	○	○	○	○	○
Enclosure	○	○	○	○	○	○
LCD	○	○	○	○	○	○
Silicone Tubing	○	○	○	○	○	○
Metal Fittings	○	○	○	○	○	○
Front Panel Label	○	○	○	○	○	○
Rating Labels	○	○	○	○	○	○

O: 表示该有毒有害物质在该部件所有均质材料中的含量均在 SJ/T 11363-2006标准规定的限量要求以下。

O: Indicates that this toxic or hazardous substance contained in all of the homogeneous materials for this part is below the limit requirement in SJ/T11363-2006.

X: 表示该有毒有害物质至少在该部件的某一均质材料中的含量超出 SJ/T 11363-2006 标准规定的限量要求。

X: Indicates that this toxic or hazardous substance contained in at least one of the homogeneous materials used for this part is above the limit requirement in SJ/T11363-2006.

I, the undersigned, hereby declare that the equipment specified above conforms to the above Directives and Standards.



Signature

Date: 30 July 2010

Braham Bassar
Director

InnovAg Pty. Ltd

Contents

1.	What is MiniTest?	3
2.	Safety Precautions	4
3.	Maintenance and Calibration	4
4.	The Front Panel.	5
5.	Vacuum – Setting up.	6
6.	Checking Vacuum	7
7.	Pulsators – Setting up.	8
8.	Checking Pulsation	9
9.	Software Version and Calibration Date	10
10.	Replacing the batteries	11
11.	Repairs	12
12.	Problems with your MiniTest	13
13.	Specifications	14
14.	Warranty	15

All rights reserved. No part of this manual may be reproduced, transmitted, stored in a retrieval system, or translated into any language in any form by any means without the written permission of InnovAg Pty. Ltd.

1. What is MiniTest?

MiniTest is a small, light, hand-held instrument for testing vacuum supplies and pulsators in dairies. It uses the same high-accuracy analysis of its ‘big brother’ DairyTest Professional, but in a smaller, lighter, lower-cost format. It is intended for use by personnel with technical knowledge of dairy operation as an accessory to a professional test kit, i.e. for bench-testing of pulsators and to do a quick check on the dairy’s performance. It has only a single vacuum port and cannot be connected to a PC or printer.

Within Australia we have a Freecall help line which is there if you have problems (**1800 061 167**). International users should call their local distributor or contact us via fax +613 9521 8009, or email info@innovag.com

2. Safety Precautions

MiniTest is intended to be used in the milking stall – always allow for the unpredictable nature of the animals.

During the measurements sharp needles may be used. Take care they do not hurt people or animals. Always ask the dairy farmer about the behaviour of the animals and milking method used.

If using **MiniTest** in wet tests, always keep the unit above the test point to prevent fluid entry. ***Damage to the unit from fluid entering the sensor is not covered under the warranty.***

3. Maintenance and Calibration

Maintenance

Clean the MiniTest with a moist cloth. Do not use cleaning agents.

MiniTest performs a self test when turned on, lighting up all segments of the LCD. If an error message is displayed (E-01 for example), or you suspect the unit is damaged, contact InnovAg or the local distributor for further information.

Calibration

MiniTest automatically performs a zero calibration when turned on.

Do not turn on your MiniTest with vacuum connected. If the unit reads other than zero on start-up a manual ‘force-zero’ feature can be used. See the ‘***Problems with your MiniTest***’ section.

A complete calibration should be performed with an approved and certified calibration test instrument every 24 months. This can be organised by InnovAg or the local distributor.

4. The Front Panel.

In Pulsation Mode **MiniTest** can measure six pulsation parameters (A+B, B, C, D ratios, rate and Max Vacuum) and provide indication of B-phase drop and pulsation stability. In Vacuum Mode three vacuum parameters are measured (Minimum, Average and Maximum). The picture below shows the front panel indicators and controls.

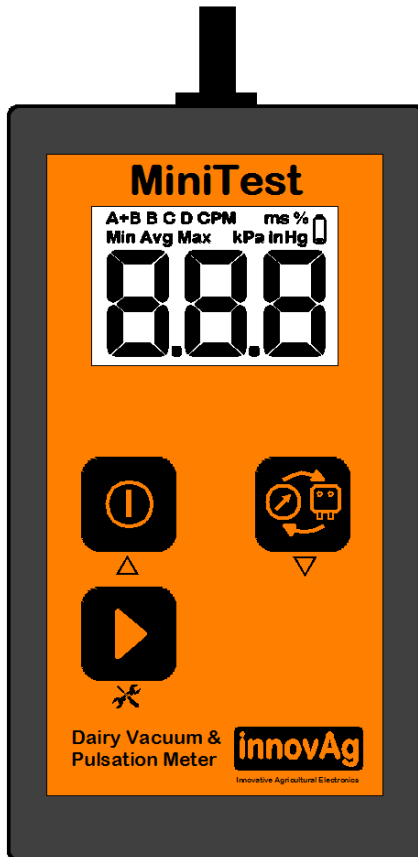





Low-Battery Indication

If the remaining battery capacity is getting low the Battery symbol will flash. Replace/recharge the batteries.

5. Vacuum – Setting up.

MiniTest can display vacuum in either kiloPascals (kPa) or inches-of-mercury (inHg) units as required. The units setting can only be changed in Vacuum mode.

Changing/checking the setting.

1. Make sure the unit is turned ON and in Vacuum mode (**Min**, **Avg** or **Max** displayed).
2. Press and hold the  key for about 3 seconds to enter setup mode. The display will show *unt* (Units).
5. Press either the  or  key to change between kPa and inHg.
6. Press the  key to save the changes and return to normal operation.

Auto Exit

MiniTest will automatically exit Setup mode after 1 minute if you don't press any keys.

Startup Mode

Vacuum mode defaults to Average (Avg) on startup. The setting is kept when the mode is changed to Pulsation but is reset when the unit is turned off or the batteries run flat.

6. Checking Vacuum

When set to Vacuum mode MiniTest will display the Minimum (Min), Average (Avg) or Maximum (Max) vacuum level on the digital display.

Press the  key until the required parameter is selected.



Auto-power OFF

If there is no vacuum on the port and you don't push any keys the unit will automatically turn OFF after 10 minutes to save battery life.





What is it measuring?

All vacuum measurements are taken over a rolling 1.6 second period, sampled 1000 times per second.

7. Pulsators – Setting up.

MiniTest can display Pulsation Ratios (A+B, B, C and D) as either percentage (%) of the total cycle, or in milliseconds (ms). The selected method applies to all ratio parameters (A+B, B, C and D). Rate measurement is fixed in Cycles-per-minute (CPM).

Changing/checking the setting.

1. Make sure **MiniTest** is turned ON and in Pulsation mode.
2. Press and hold the  key for about 3 seconds to enter setup mode. The display will show rAt (Ratio).
3. Press either the  or  key to set the required Ratio display method; percentage (%) or milliseconds (ms).
4. Press the  key to save the changes and return to normal operation.

Auto Exit

The tester will automatically exit Setup mode after 1 minute if you don't press any keys.

Saved Settings

Settings are kept until changed by you. They do not reset when the unit is turned off or the batteries run flat.

8. Checking Pulsation

MiniTest can display Pulsation Ratios **A+B**, **B**, **C** and **D** as well as Rate (in CPM).

Press the  key until the required parameter is selected.



Note: Use Vacuum Mode to measure Maximum Vacuum of the pulsation waveform.

Stability Indication

If the current reading varies from the average by more than 5% then the pulsation being measured is not stable. '**Avg**' will flash to warn the user to wait until the readings settle. If '**Avg**' does not stop flashing there is a problem with the pulsation being measured.

B-Phase Drop Indication

If a vacuum drop of more than 4kPa is detected within the B Phase then the pulsation is not within ISO specification and '**B**' will flash to warn the user.

Auto-power OFF

If there is no vacuum on the port and you don't push any keys **MiniTest** will automatically turn OFF after 10 minutes to save battery life.

What is it measuring?

All Pulsation measurements are taken using 4kPa thresholds, sampled 1000 times per second. Readings conform to ISO standards by averaging over 5 cycles. A 'rolling' system is used where measurements from the current cycle and the four previous ones are averaged together, which means ISO requirements are met while the screen still continuously updates.

9. Software Version and Calibration Date

To display both **MiniTest** 's software version number and last Calibration Date use the following sequence:

1. With **MiniTest** turned off, press and hold all three buttons. After 3 seconds the display will show the version number, e.g. *P01* means Program version 01.
2. Release the buttons.
3. The last Calibration date will then be shown in 4 steps:

- [AL* Calibration date follows.
- 23-* Calibration **Day**, e.g. 23rd.
- *11* Calibration **Month**, e.g. November.
- *10* Calibration **Year**, e.g. 2010.

10. Replacing the batteries

When it's time to replace **MiniTest**'s batteries, the battery symbol will start to flash. We recommend the batteries be replaced as soon as possible once the low battery indicator starts to prevent unreliable readings or operation.

Batteries should not be left in the unit for extended periods in case of leakage. Use quality Alkaline or NiMH 'AA' rechargeable cells.

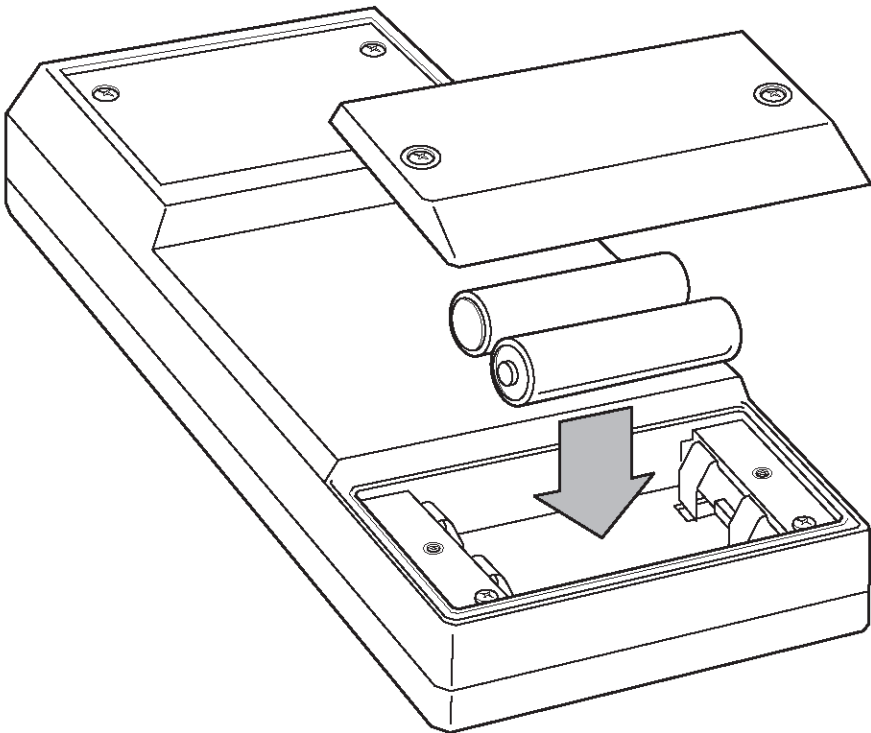

11. Repairs

DO NOT OPEN THE CASE – THERE ARE NO USER SERVICABLE PARTS INSIDE AND YOU MAY VOID YOUR WARRANTY. Defective units should always be sent to InnovAg or your nearest distributor.

Smaller repairs that can be performed by your distributor are:

- Changing parts of the housing.
- Replacing hoses
- Calibration (only if a certified original calibrator is used)

For other defects, please contact the manufacturer for further instructions:

InnovAg

82 Victoria St.

Sandringham

VIC 3191

Australia

Ph. +613 9521 9383

Fax +613 9521 8009

email: info@innovag.com

12. Problems with your MiniTest

Before returning your **MiniTest** for repair, check the following:

- The unit does not turn on or won't stay on – replace batteries.
- The Battery symbol is flashing – Batteries are getting low.
- **MiniTest** reads vacuum with no vacuum connected – Disconnect from the vacuum supply and turn it off and on again to reset the zero.
- Damaged **MiniTests** should be returned for repair. There are no user serviceable parts inside the case, and opening it may void your warrantee.
- If you have a question or problem you cannot solve, contact InnovAg or your local distributor.

13. Specifications

Pulsation:

- Rate Range: 40 to 500 CPM.
Rate accuracy: $\pm 0.5\%$.
Ratio accuracy: $\pm 0.5\%$ of calculated value.
Time (ms) accuracy: $\pm 0.3\%$.
Sample rate: 1000 samples/sec.

Pressure:

- Range: +10 to -80 kPa at 1 atm.
Accuracy: ± 0.5 kPa
Repeatability: ± 0.3 kPa
Resolution: 0.1 kPa

General:

- Operating Temperature: 5 to 45°C
Storage Temperature: 0 to 60°C
Automatic turn-off time: 10 minutes after last key press
if no vacuum on port.
Batteries: Two 'AA' Alkaline or
NiCd/NiMH rechargeable cells.
Operating voltage: 1.4V to 5VDC

Specifications are subject to change without notice.

14. Warranty

InnovAg Pty. Ltd. (“INV”) provides the following limited one-year warranty (“Warranty”) to the original purchaser (“Purchaser”) of MT (“Product”). This warranty cannot be assigned or transferred to subsequent purchasers. The registration form must be completed and returned to INV in order to be able to claim under this Warranty.

WHAT WE WILL DO

If MT (“Product”) fails under normal use and service because of a manufacturing defect in materials or workmanship within the warranty period, INV will, at its option either repair or replace the Product with an equivalent product. The repaired or replacement product will be warranted under the terms of this Warranty for the remainder of the applicable warranty period. Repair may include the replacement of parts or components with functionally equivalent reconditioned parts or components.

WARRANTY PERIOD

The term of this warranty is one (1) year from the date of purchase.

WHAT IS NOT COVERED

This Warranty does not cover any failures of equipment not supplied by INV, nor does it cover any failures of or damage to the Product due to:

- (i) improper handling, misuse, neglect, accident, improper installation, non-compliance with the directions for use;
- (ii) any internal or external alteration or modification of any kind which in the opinion of INV will affect the ability to service the Product; or
- (iii) repair by anyone other than an authorised InnovAg Service Centre.

RIGHTS UNDER THE TRADE PRACTICES ACT

Under applicable State, Territory and Commonwealth law, certain conditions and warranties may be implied in this contract and rights and remedies conferred upon you as user in relation to the Product which cannot be excluded, restricted or modified by agreement (“Non-excludable Rights”). Any rights conferred upon you by this Warranty are in addition to and do not detract from those Non-excludable Rights.

INV disclaims all express or implied conditions and warranties in relation to the Product other than the express terms of this Warranty and any Non-excludable Rights. With respect to Non-excludable Rights, INV’s responsibility to the Purchaser, where permitted, is limited to the undertakings as stated in the clause headed ‘WHAT WE WILL DO’.

Subject to the above, in no event shall INV be liable (whether before or after discharge of the contract for supply of the Product or otherwise) for any loss or damage suffered by you as the user arising from or caused or contributed to by the negligence of INV, its servants or agents, nor shall INV be liable for special, incidental, indirect or consequential loss or damages suffered by you as user as a result of breach by INV of this Warranty or otherwise including but not limited to economic or moral loss, loss of profits or revenue or costs arising from the loss of use of the Product or the cost of substitute products.