



V14 Software Release

Vacuum Recorder for DairyTest Professional

This release is a major upgrade adding the following features to DairyTest Professional units:

- ? 2 channel Vacuum Recorder with sophisticated fluctuation log and ISO stability readings.
- ? Memories for Ammeter and Tachometer.
- ? Ratios available as % or ms.
- ? Reading stability indication in Pulsation test mode.

Your copy of the V14 software upgrade follows, along with excerpts from the new manual on how to use these features. A copy of the full manual is available for \$20.

If you require us to update your unit for you, please return your DairyTest unit with a cheque for \$25 to our address below.

Important Note.

When upgrading a DairyTest Professional to Version 14 from any earlier version any previously saved memories in the DairyTest will not display the graph correctly.

The problem occurs because the database format is different in Version 14 from all previous versions. Memories recorded under Version 14 will display correctly. Note that Farm names are undisturbed.

We recommend the following be performed before updating to version 14:-

If using DTPC:-

1. Upload existing memories into a PC using DairyTest PC, V1.6 or later.
2. Clear all memories in the DairyTest using the "CLEAR" function in the "SETUP" menu.
3. Update the new software using the "dtupdate" program.

Otherwise, print out all memories you wish to keep a record of using the DairyTest printer.

InnovAg Pty. Ltd. (Formerly DairyTest Technologies Pty. Ltd.)

82 Victoria St., Sandringham 3191 Victoria Australia

Ph +613 9521 9383 Fax +613 9521 9357 Email: dairytest@cpdesign.com.au

ACN 073 191 376

DairyTest Professional.

Release Notes for Software Version 14.

The following notes describe features and corrections introduced in Software Version 14 that were not in Version 12D. If you have upgraded from software earlier than Version 12D copies previous Release Notes are available on request.

New Features:-

1. A Vacuum Recorder function has been added under the AUX menu. Records both vacuum lines for up to 30 minutes and shows fluctuations that have occurred during that time. One recording can be saved per farm. *-To the many people that have been asking for this, sorry it took so long to arrive! Let us know if you have any suggestions to improve it.*
2. Memories are now included for Tacho and Amps functions to allow readings to be saved with a farm. Mainly added for Version 2 of DairyTest PC, so that all readings can be saved for printing on the new Test Report form.
3. Ratios can now be displayed in either % or ms, selectable from the SETUP-SYSTEM screen. Current setting shown on right-hand side of main screen and on pulsation mode labels.
4. When a Pulsation reading is saved, DairyTest can be set to automatically increment either one or two memories, as set under the SETUP-SYSTEM screen. *-Thanks to Rob Cosson for this suggestion.*
5. The D Time measurement threshold is now selectable to either 2 or 4 kPa (previously fixed at 2kPa), set under SYSTEM-SETUP menu. *-Rather than get caught-up in the long-time argument over which is the best, we took the easy way out and made it selectable. Now you can make your own choice (ISO specifies 4kPa). Make sure you check if the setting is what you want!*
6. Pulsation readings are now averaged over 5 cycles in accordance with ISO specifications. Previously readings were calculated from one cycle. New system uses a 'first-in-first-out' averaging method, calculated over current plus previous 4 readings; so display still updates after each sample. This approach will also hide some of the minor cycle-to-cycle variation highlighted by the previous method.
7. Displayed/printed graphs now have vertical axis on right-hand side, as well as left, making it easier to gauge vacuum levels near the right-hand side.
8. The accuracy of the unit at low vacuums (< 5kPa) has been improved by a change in the calibration system.
9. If Alarms are turned ON, a mark will be printed beside those readings that are not within spec. Previously alarms were shown on the screen only.
10. Printing system has been changed so that you can use the meter for other functions while the printer is operating. For the techos – a one-normal-graph size buffer has been added along with background printing. DairyTest will still make you wait if printing entire farms or full Vacuum Recorder graphs.
11. Communications with a PC can now be done from any menu level. Previously DairyTest had to be in MAIN MENU.
12. The little blinking dot in the top right-hand corner, which was mainly for our testing purposes, has been removed. Some users asked what it was. It was easier to remove it than explain it.
13. The internal Boot program version number is now displayed on the top right-hand corner of the DAIRYTEST startup screen. No use during normal operation, but it helps us tell what version of unit you have if you ring with a problem.

14. If the pulsation readings on either port are varying by more than 5%, that port's label (eg. P1) on the screen will be 'blacked out'. Keep an eye on the P1 and P2 labels. If they are 'blacked' the readings have not stabilised yet. Wait a few seconds to see if the blacked area clears. If it doesn't then your pulsation waveform isn't stable. *–Thanks to David Shields for this suggestion.*
15. When editing a farm name on DairyTest you're asked 'Are you sure?' after pressing the 'CLR' key to erase the entire name. Stops the name being cleared if the button is pressed by accident *-Thanks to Rob Cosson for this suggestion.*
16. Memories have been reduced from 436 to 420 to allow us to fit some of the new features.
17. The DairyTest can now be used while Charging. Note that only SETUP can be used while Discharging.
18. Pulsation mode can now be set to display either Limping (difference between A+B of both ports) or Balance (difference between B-only of both ports), selectable from the SETUP-SYSTEM screen. Limping may show a pulsator as being correct, whereas the two sides may have totally different B phases. Balance measures only the difference in the B phase, therefore will highlight more problems with 2x2 pulsators. *– Thanks to Rob Cosson for this suggestion.*
19. The Software version number is now displayed on the bottom of the 'SETUP' screen to make it easier to check which version you have. Previously it was only shown on the 'DairyTest' screen that flashed up when DairyTest was turned on.

Problems Fixed:-

1. A problem with the AC AMPS function in Version 12C caused the readings to be high, or lock the display on about 60.0A. The function now reads correctly. Note that the zero adjustment on the tong-meter probe needs to be set for both AC and DC ranges. *-Thanks to Rob Cosson for detecting this one.*
2. The internal valve system now automatically moves the servo to the 'Flush' position when DairyTest is turned off. Some users experienced reading problems when first turning their DairyTest on after a long period of no use. The internal silicone-rubber hoses were sticking shut from being left crushed for several months. Although the hoses eventually recovered, the new method leaves the hoses un-crushed when not in use, to make the unit usable straight away and increase hose life. *–Thanks to the guys from the VDIA and NSW Dairy Corp. for bringing this one to our attention.*
3. A problem in Pulsation mode which caused the unit to read a Limping value of around 1% when on a 4 x 1 pulsator, has been corrected. Also caused the A% of the current port to read about 1% lower than the other port. Limping will now read 0 and A% figures will be correct. *–Thanks to David Shields for finding this one.*
4. The automatic re-calibrate on temperature change was not functioning correctly. DairyTest will now automatically re-calibrate its sensors if its internal temperature changes by more than 5°C (you'll hear the valve operating).

Please give us a call (Australia - toll free 1800 061 167, International - via fax on +613 9521 9357) if you have any suggested new features or suspected problems with DairyTest. We can only keep improving the product if you keep the feedback coming.

Quick Start.

How to Test Pulsators

1. Set the how the results are calculated.

Set units for Vacuum (kPa/inHg) and Pulsation ratios (%/ms) and the vacuum threshold used to calculate the D-phase time **DSEC** (2 or 4Kpa/0.5 or 1.1 inHg). Also decide how the difference between ratios of a 2 x 2 pulsator is displayed, Limping **LMP** or Balance **BAL** (see **Changing the Clock, Contrast, Units, Keybeep and Pulsation Settings**).

2. Connect the hoses to the pulsator.

From the Main Menu select Pulsation mode (**PULS**). The graph should appear on the screen and automatically updates every few seconds.

3. Check the readings have settled.

The port indicator (**P1** or **P2**) will be drawn in reverse (ie. **P1** or **P2**) if the pulsation is unstable (any value is more than 5% different from the average). Wait until the port indicator is drawn normally before saving or printing the readings. If the reverse does not clear it is likely that the pulsator has a problem.

4. Select what is shown on the screen.

The current port is the solid line on the graph and its readings are on the right side of the screen. Press the **P1** (or **P2**) button to view the other port (see **Swapping between Port 1 and Port 2**). Alternatively you can change to DIGITAL display by pressing the **8.88** button (see **Swapping between GRAPHIC and DIGITAL displays**). DIGITAL shows all readings at once with one in large digits, useful if you are adjusting a pulsator.

5. Increasing the graph time.

The graph can be recorded over 1.5 or 3.0 seconds. Press **SEC** to change the scale (see **Changing the Timebase**). Changing the scale does not alter the sample rate or accuracy of the readings. The scale cannot be changed on a saved graph.

6. Printing the results.

Press the **PRINT** key. In Quick Mode what is on the screen is printed. In Expert Mode you can select the print format.

7. Using the Alarms (Expert mode only).

Readings not within preset limits can be automatically highlighted eg. **B%=21.3**. There is a default set of alarms and individual settings are stored for each farm (see **Farms**). Turn alarms ON/OFF by pressing **ALARM**. Hold the key down to see the current settings.

8. Saving the readings (Expert mode only).

Press **MEM** to enter Memory mode (see **Memories**). The current Stall is shown in the title. The **MEM** symbol means the memory is already used. Updating continues while in Memory mode. Press **M+** to save the readings. Data and graphs for both ports are stored in one memory. Use the arrow keys to move to the next Stall, or if Auto Increment is ON the number will move forward after each save (see **Changing the Clock, Contrast, Units, Keybeep and Pulsation Settings**). All saved readings can be printed later (see **Printing from Memory**). Press **MR** to view the memory.

Changing the Clock, Contrast, Units, Keybeep and Pulsation Settings

DairyTest has several settings that control the way the meter operates. In general these do not need to be changed often.

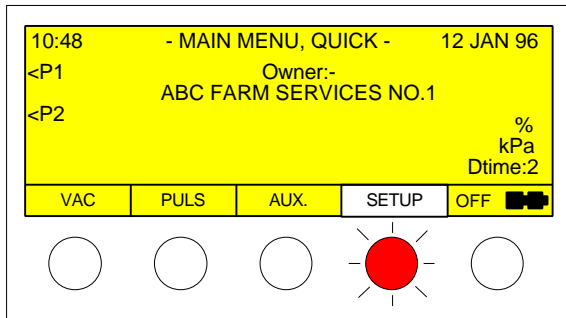

Select Setup menu.

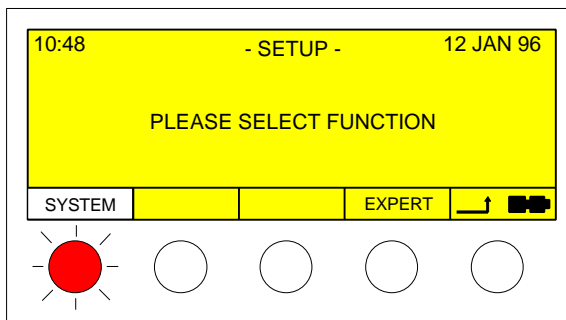

Select System menu.

For more information on all settings, see 'What the settings mean' in the next section.

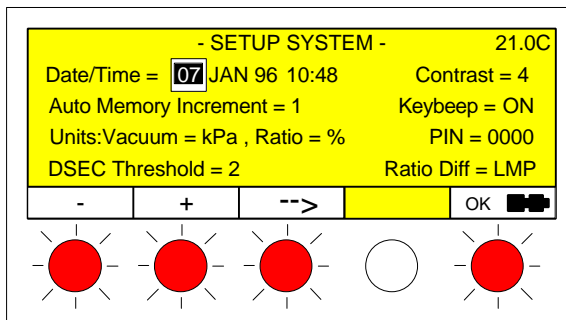

- ① Decrement setting.
- ② Increment setting.
- ③ Move cursor to next item.
- ④ Accept changes.

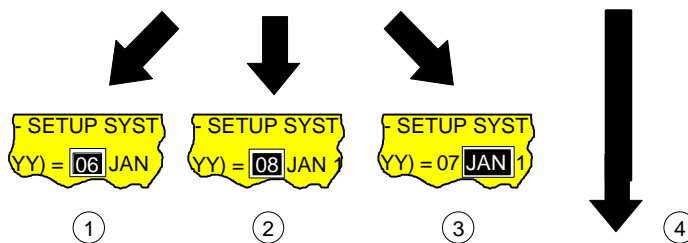

If you miss a setting, or make a mistake, push the button until the cursor returns to the item you want to change.

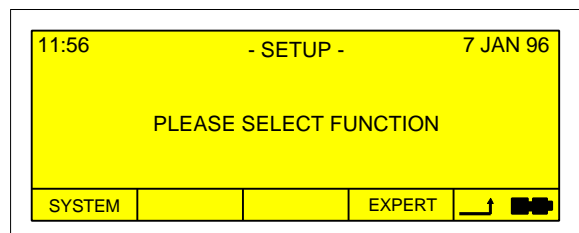

What the Settings mean

Date/Time: Sets the DairyTest internal clock. Use 00 for 2000.

Contrast: Controls the difference between light and dark parts of the display. Darkest = 15.

Auto Memory Increment: Allows the pulsation memory to move forward automatically after each save.

0 = No increment.

1 = Increment by one, the Stall will move 1A, 1B, 2A, 2B.....

2 = Increment by two, the Stall will move forward 1A, 2A, 3A.....

Keybeep: Sets if a beep is heard each time a key is pressed.

Units: Allows the DairyTest to display in different measurement units. Vacuum as inHg or kPa; pulsation ratios as a percentage of the total cycle (%) or actual milliseconds (ms).

PIN: Used to change the PIN and Owner Name. See the next section for more detail.

DSEC Threshold: Used to set the vacuum level that Pulsation mode uses to calculate DSEC. Can be set to either 2kPa (0.5inHg) or 4 kPa (1.1inHg), the same as that used for ratio calculation.

Ratio Difference: Sets which Ratio Difference value is shown on the screen in Pulsation mode. Normally set to Limping (LMP) which is the difference between the A+B (BPR) of Port 1 and Port 2. The Balance option (BAL) is the difference between the B phases only, and can be useful to quickly highlight a problem in the A phase of one port where the A+B value may be correct.

Saving Tachometer readings

1. Displays current memory
2. Memory empty.
3. Memory used.
4. Moves through list of memories shown on right.
5. Saves readings to current memory in current farm.
6. Tachometer has 4 memories,

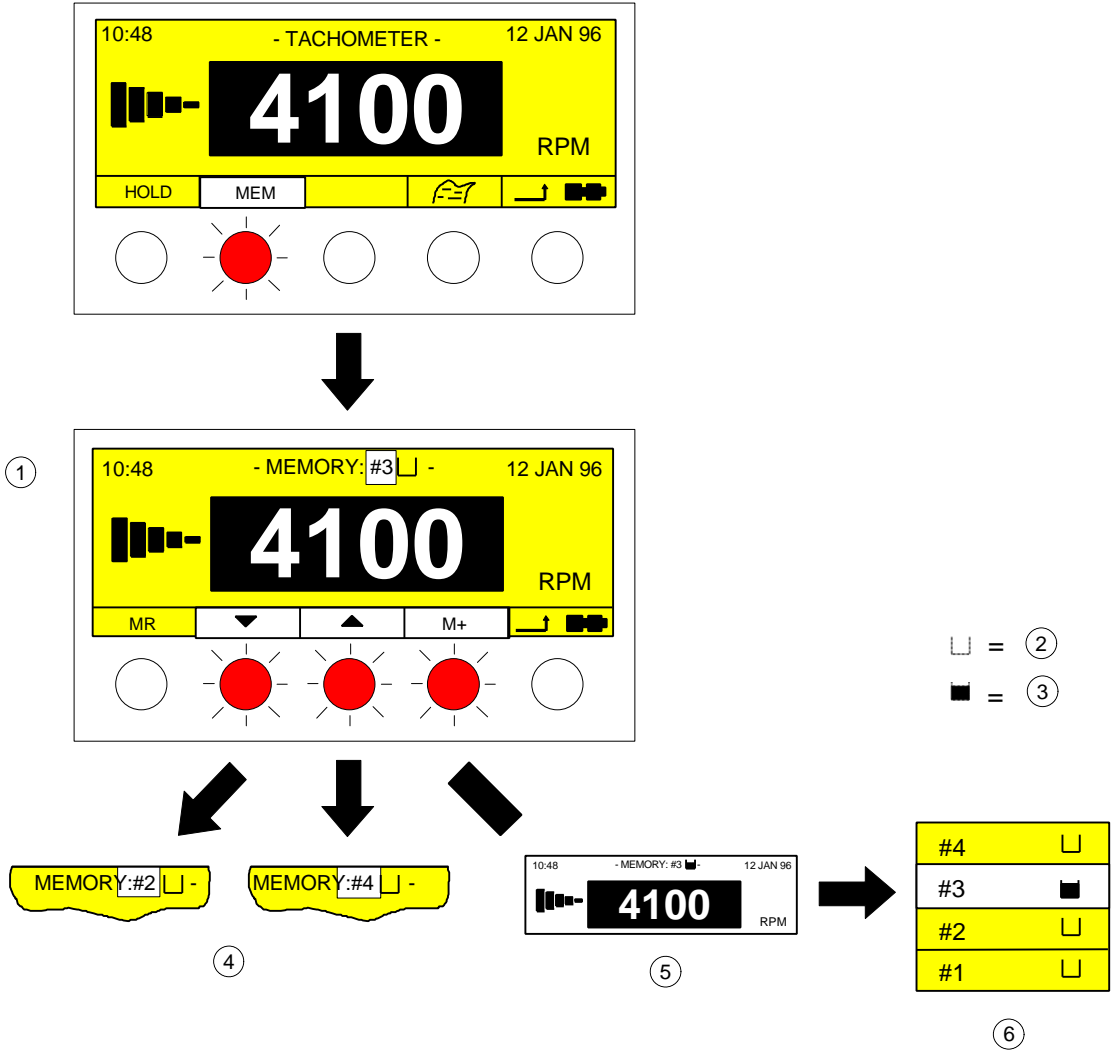

Recalling Tachometer readings

Memory Recall (MR) is used to view data previously saved to memory (only memories that have been used can be viewed).

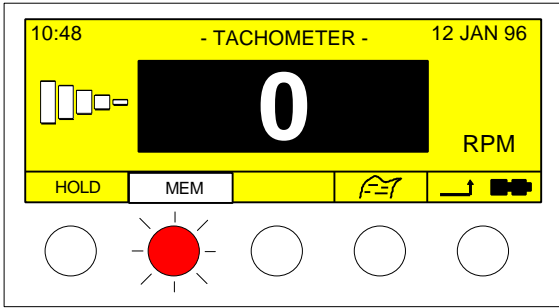

Select Memory Recall (MR) mode. Memory Recall mode only operates when at least one memory in the current farm has been used.

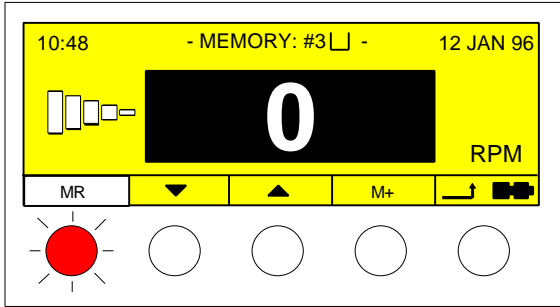

Memory Recall mode can be identified by the date and time in the title.

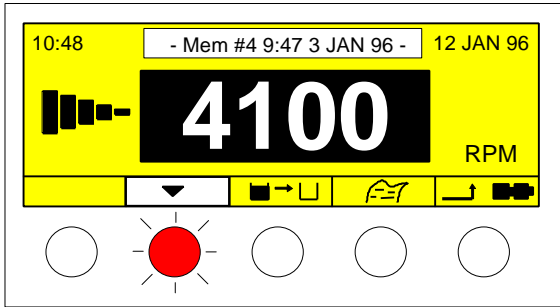

- 1. Moves display through list of used memories. See example below.
- 2. Memory empty.
- 3. Memory used.

①

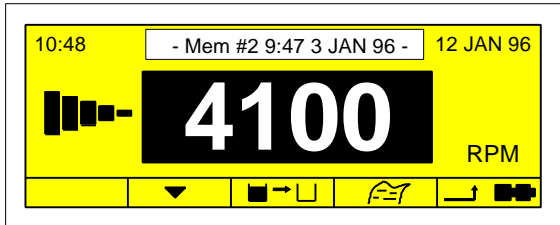

e.g.:

□ = ②	#4	■
■ = ③	#3	□
	#2	■
	#1	■

UK

Expert

Erasing Farm Memories - Tachometer

Tachometer Memory Recall

Select farm whose memories you want to erase.

From Tacho select MEM, then MR.

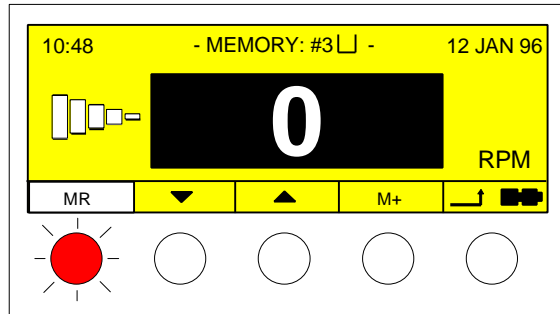

Select erase (left arrow, right arrow).

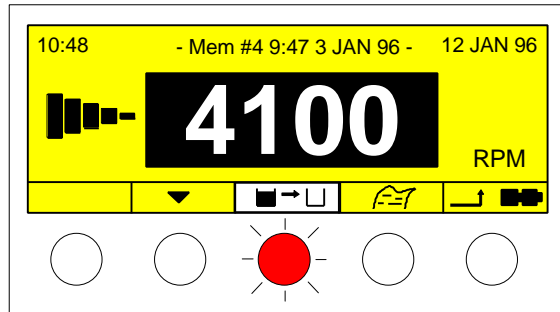

Confirm erase.

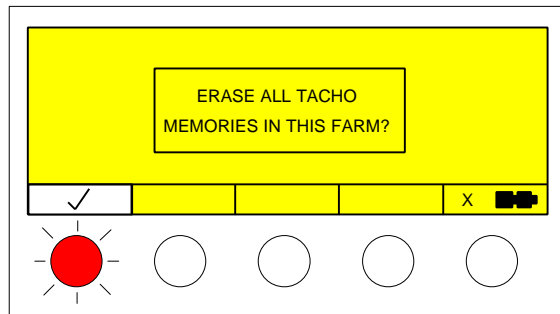

Memories erased.

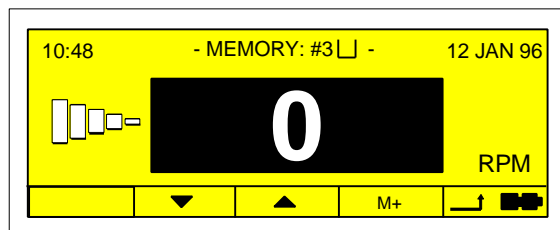

The Vacuum Recorder provides long-timebase 2-channel vacuum recording. Readings are automatically saved to memory for later viewing, and you can view the recorded chart **whilst still recording**.

Vacuum lines can be monitored for changes (fluctuations) from an absolute vacuum, shifts from the average level (taken over the last 30 seconds). Details of the worst error conditions along with the total number of fluctuations and vacuum stability are recorded for each channel.

Each Farm can have one Vacuum Recording which uses up to 21 DairyTest memories. DairyTest will warn you if less than 21 memories are available when the Vacuum Recorder is started.

The following conventions and abbreviations are used for the Vacuum Recorder:

WDS: Widest Duration, Seconds.
Duration of widest fluctuation.

WDV: Widest Duration, Vacuum level. Minimum vacuum of widest fluctuation.

DPS: Deepest Duration, Seconds.
Duration of deepest fluctuation.

DPV: Deepest Duration, Vacuum level. Minimum vacuum of deepest fluctuation.

NUM: Number of fluctuations since recording started.

%OK: Percentage of time that vacuum level has been above the LIMIT setting.

Absolute Model \ Mode absolu \ Absolut-Modus \ Modo Absoluto -

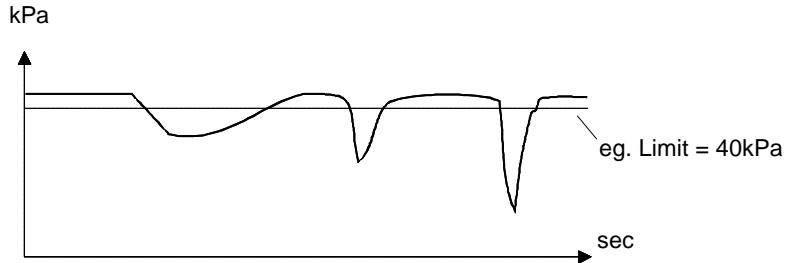

Relative Model \ Mode relatif \ Relativ-Modus \ Modo Relativo -

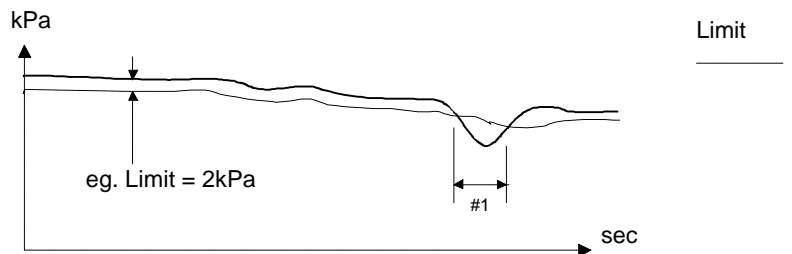

Example Recording \ Exemple denregistrement \ Beispiel-Aufzeichnung \ Registro de Ejemplo -

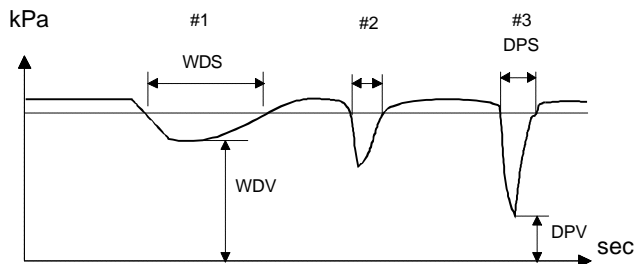

P1	- VACUUM RECORDER -	P2
NUM = 3	MODE = RELATIVE	NUM = 0
DPV = 35	LIMIT (KPA) = 2	DPV = 0
DPS = 0.6	SCALE (sec) = 15s	DPS = 0
WDV = 42	TRIG. START = OFF	WDV = 0
WDS = 14	REC. TIME: 5 min.	WDS = 0
%OK = 97.8		%OK = 0.0
REC		SETUP

Setting up the Vacuum Recorder

Select Auxiliary menu.

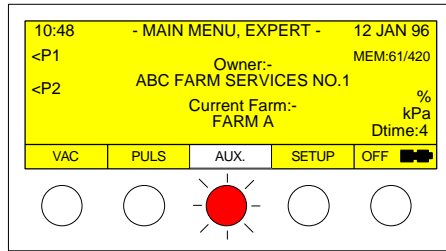

Select VACREC.

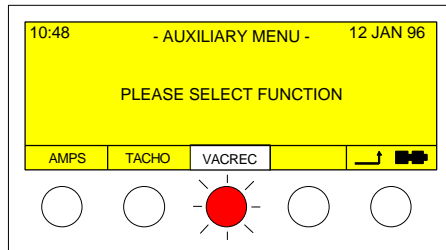

Select SETUP.

Note: Entering SETUP will erase previous recording.

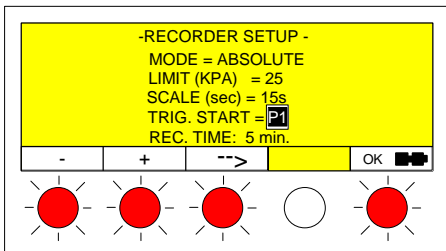
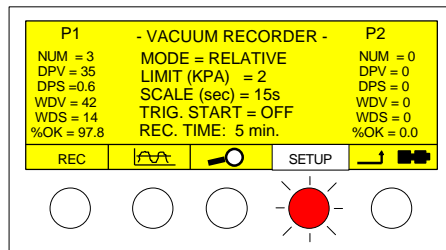

- ① Decrement setting.
- ② Increment setting.
- ③ Move cursor to next item.
- ④ Accept changes.

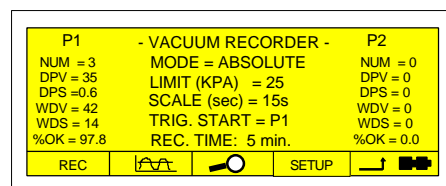
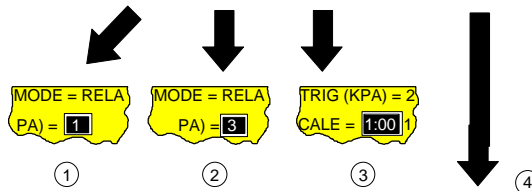

Setting up the Vacuum Recorder (cont.)

There are 4 settings that can be configured in SETUP; MODE, LIMIT, SCALE and TRIG. START.



MODE sets the trigger mode to Absolute or Relative.

Absolute mode uses the LIMIT setting as the minimum vacuum below which a reading is considered a fluctuation. Use this mode when testing for ISO-spec. compliance or when the plant parameters are well defined and the vacuum source is stable.

Relative mode uses a 30 second moving average. A drop greater than the LIMIT setting below the moving average is considered a fluctuation. Relative mode is useful when initially setting up a plant or where the vacuum supply drifts slowly over time.

SCALE sets the time per screen to 15, 30 or 90 seconds.
REC. TIME shows the total recording time for the selected SCALE setting.

TRIG. START turns the trigger on for either P1 or P2, or OFF. TRIG. START is useful when you want to record a fluctuation at the fastest scale (15s). Set the LIMIT to the vacuum level required and recording will start when the trigger port (P1 or P2) FALLS below that level.

P1	- VACUUM RECORDER -	P2
NUM = 3	MODE = RELATIVE	NUM = 0
DPV = 35	LIMIT (KPA) = 2	DPV = 0
DPS = 0.6	SCALE (sec) = 15s	DPS = 0
WDV = 42	TRIG. START = OFF	WDV = 0
WDS = 14	REC. TIME: 5 min.	WDS = 0
%OK = 97.8		%OK = 0.0
REC		SETUP 

Starting and Stopping the Vacuum Recorder

Select Auxiliary Menu

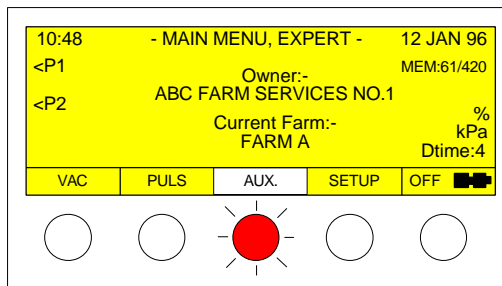

Select VACREC

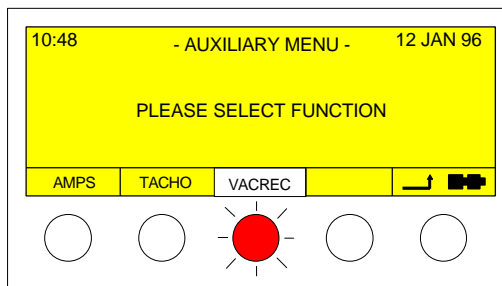

Start Vacuum Recorder

Note: Starting a recording will erase the previous recording.

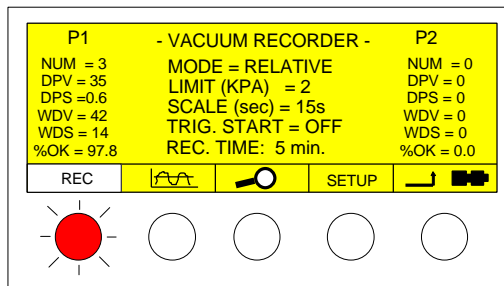

Stop Vacuum Recorder

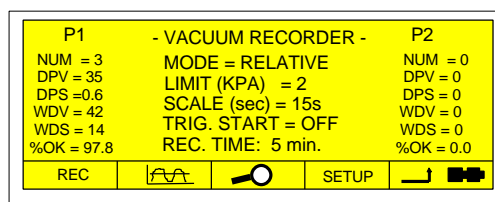
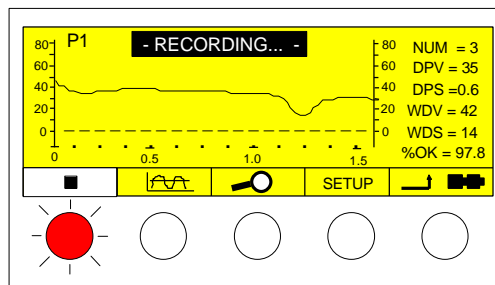

Swapping between Graphic and Digital displays

You can select the display mode either during or after a recording. In graphic mode the data displayed is that for the current port.

The Digital display shows readings for both ports, whereas Graphic mode shows the recorded graphs and data for one port only.

DIGITAL

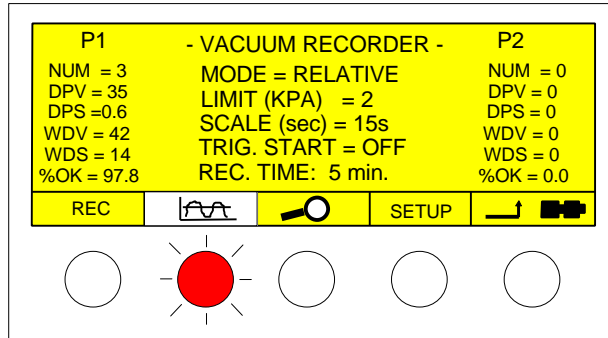

GRAPHIC

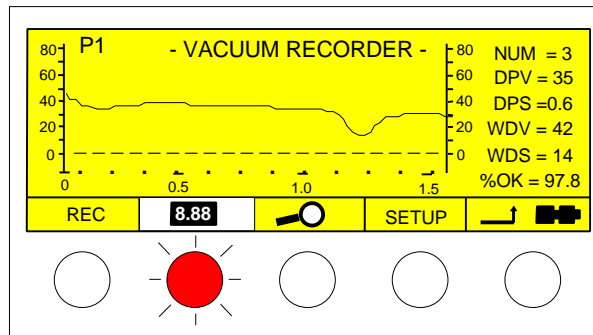

DIGITAL

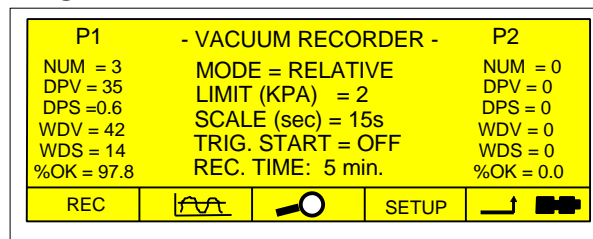

Viewing a recording

Data can be viewed whilst recording is being performed, or after it is completed.

If View mode is selected during a recording, a 'snap-shot' of the recording up to that point in time is taken and displayed. You can scroll through the 'snap-shot', but no analysis of the data is available.

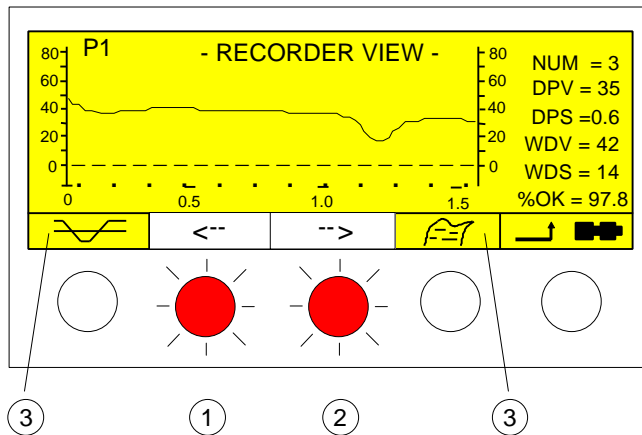
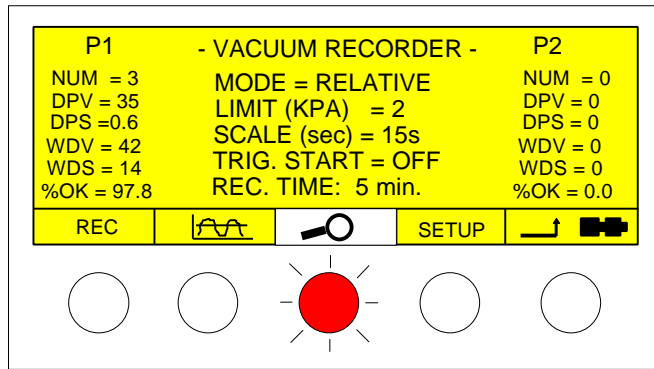
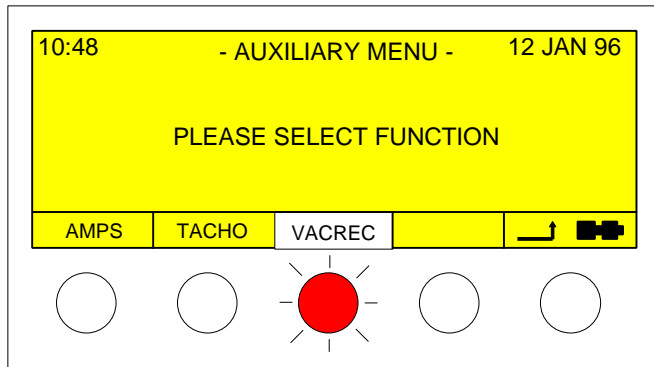

From the Vacuum Recorder menu, select view ().

1. Moves VIEW left. (Graph moves to right)
2. Moves VIEW right. (Graph moves to left)
3. Print and search functions not available during recording. Only shown when recording has stopped.

Searching For Fluctuations

Fluctuations that fall below the LIMIT setting can quickly be found using the Find-Next (▶) and Find-Last (◀) keys in the Recorder Search menu.

From Vacuum Recorder, select View (🔍).

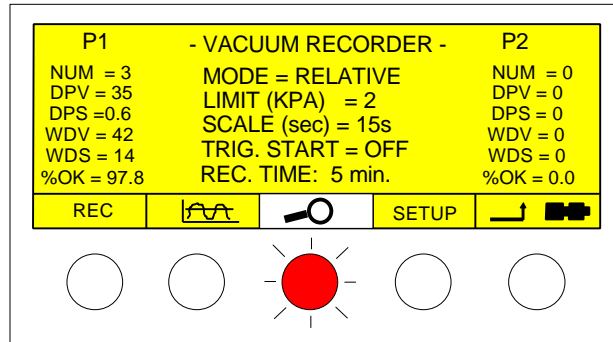

Select Search (📊).

1. Find-Next (▶). Cursor moves to next fluctuation.
2. Find-Last (◀). Cursor moves to last fluctuation.

Vertical dotted cursor lines show beginning and end of fluctuation. Data displayed at right of screen is updated as the cursor is moved through the recording.

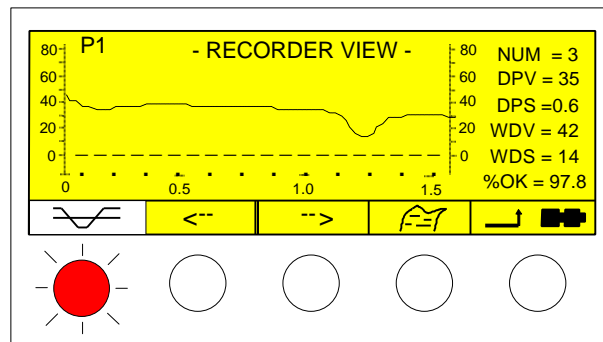

FLN - Fluctuation number.

VAC - Lowest vacuum level during fluctuation.

SEC - Duration of fluctuation, in seconds.

LMT - Limit setting. Varies for Relative mode.

%OK - Vacuum levels to beginning of fluctuation that have been above the LIMIT setting, as a percentage of total recording time.

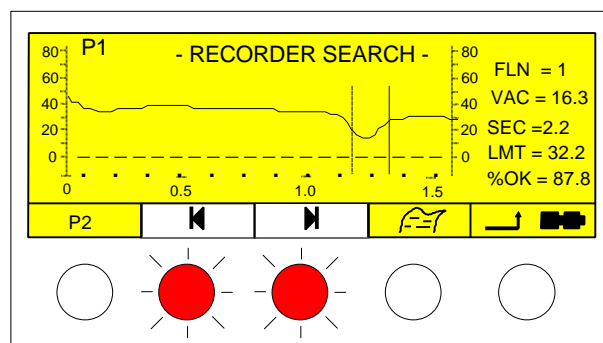

①

②

Changing Port view

The Vacuum Recorder samples both Ports using the same setup information.

The current port will be the same as that when last in Vacuum Recorder mode.

From the Vacuum Recorder select View ().

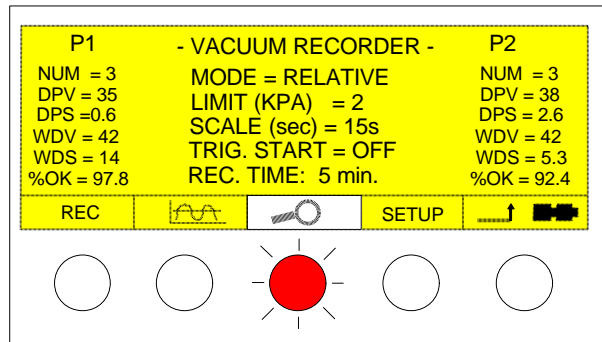

- 1. Current Port.
- 2. Current port's data.

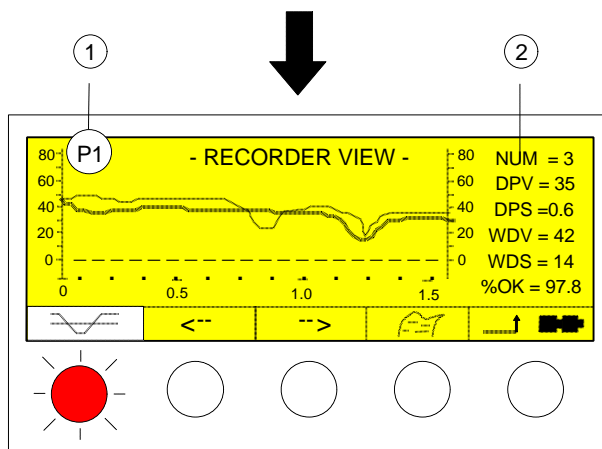

Select Search ().

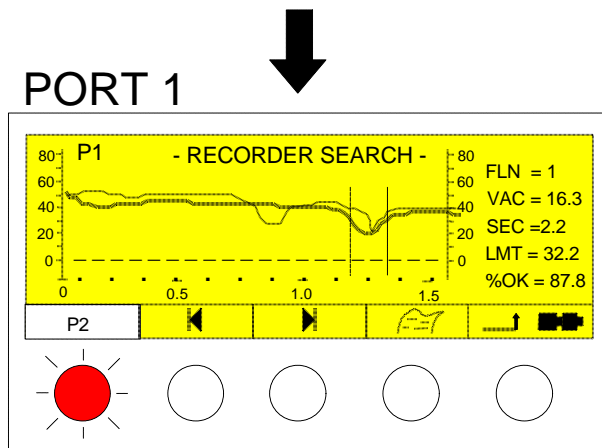

Changes view to Port 2. Sets current port for Vacuum Recorder mode. Non-current port is shown dotted.

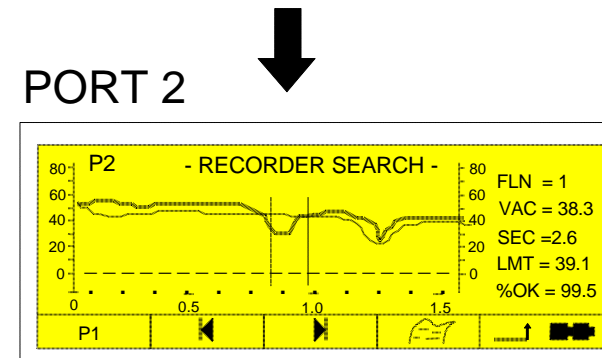

Push P1 to view Port 1.

Printing a recording

A Recording can be printed as summary data, current screen view or graph of the whole record.

From Vacuum Recorder select View (🔍), then Print (🖨️).

1. Summary data only (8.88).
2. Current screen graph and summary data (📊).
3. Whole recorded graph and summary data (📄).

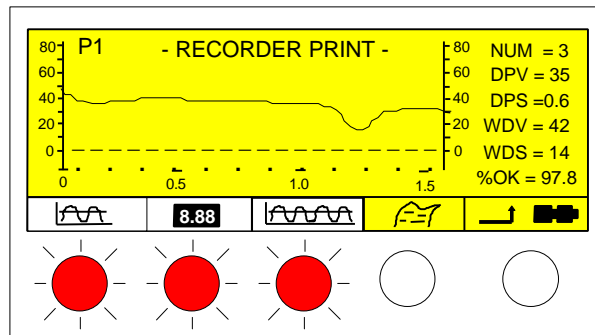
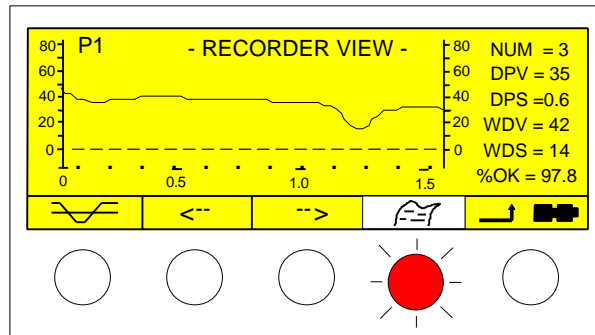
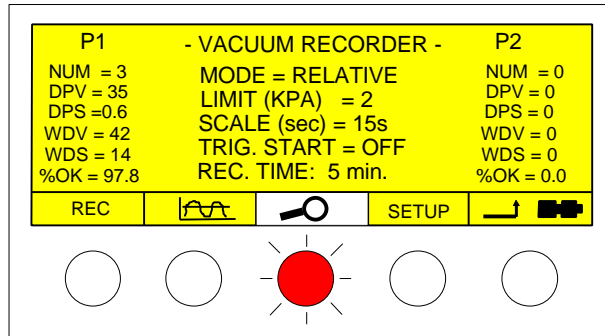

2

1

3

1

DairyTest
 ABC FARM SERVICES NO.1
 FARM A
 9:52 3 JAN 96
 Vacuum Recorder
 MODE = RELATIVE
 LIMIT (KPA) = 20
 SCALE (sec) = 15s
 TRIG. START = OFF
 REC. TIME: 5 min.

	P1	P2
NUM =	3	0
DPV =	35	0
DPS =	0.6	0
WDV =	42	0
WDS =	14	0
%OK =	47.8	0

2

DairyTest
 ABC FARM SERVICES NO.1
 FARM A
 9:52 3 JAN 96
 Vacuum Recorder
 MODE = RELATIVE
 LIMIT (KPA) = 20
 SCALE (sec) = 15s
 TRIG. START = OFF
 REC. TIME: 5 min.

	P1	P2
NUM =	3	0
DPV =	35	0
DPS =	0.6	0
WDV =	42	0
WDS =	14	0
%OK =	47.8	0

3

DairyTest
 ABC FARM SERVICES NO.1
 FARM A
 9:52 3 JAN 96
 Vacuum Recorder
 MODE = RELATIVE
 LIMIT (KPA) = 20
 SCALE (sec) = 15s
 TRIG. START = OFF
 REC. TIME: 5 min.

	P1	P2
NUM =	3	0
DPV =	35	0
DPS =	0.6	0
WDV =	42	0
WDS =	14	0
%OK =	47.8	0

Printing a recording (cont.)

A fluctuation can be printed as summary data or current screen view.

From Vacuum Recorder select View (🔍), Fluctuation (📈), then Print (🖨️).

1. Summary data only (8.88).
2. Current screen view and summary data (📈).

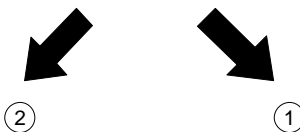
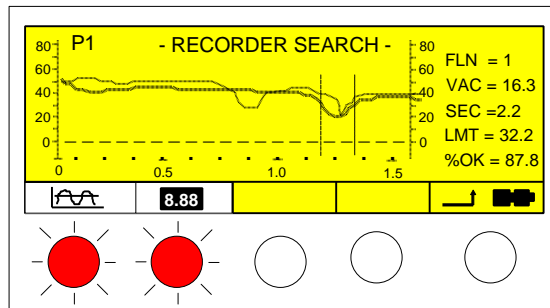
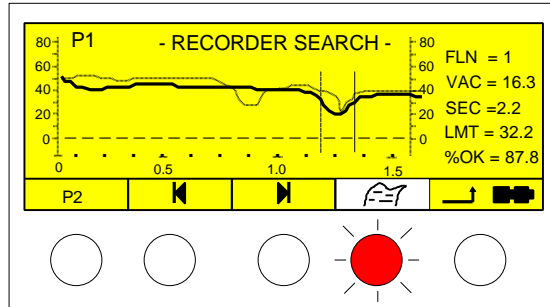
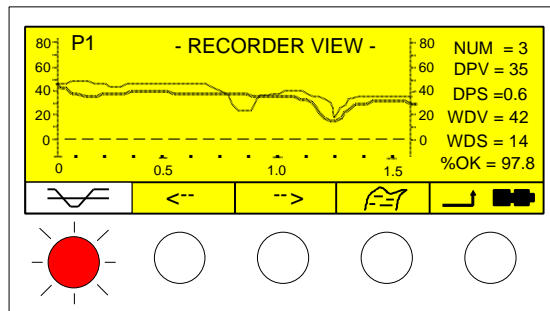
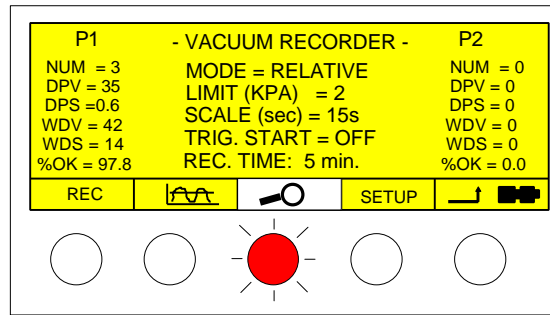

1

DairyTest
 ABC FARM SERVICES NO.1
 FARM A
 9:52 3 JAN 96
 Vacuum Recorder
 MODE = RELATIVE
 LIMIT (KPA) = 20
 SCALE (sec) = 15s
 TRIG. START = OFF
 REC. TIME: 5 min.

	P1	P2
FLN =	1	0
VAC =	16.3	0
SEC =	2.2	0
LMT =	32.2	0
%OK =	87.8	0

2

DairyTest
 ABC FARM SERVICES NO.1
 9:52 3 JAN 96
 Vacuum Recorder
 MODE = RELATIVE
 LIMIT (KPA) = 20
 SCALE (sec) = 15s
 TRIG. START = OFF
 REC. TIME: 5 min.

	P1	P2
FLN =	1	0
VAC =	16.3	0
SEC =	2.2	0
LMT =	32.2	0
%OK =	87.8	0

